

PERFORMANCE DATA SHEET NEMA PREMIUM NR CAN NEMA 12 - 12

Catalogue #: MPP-96

HP	kW	Voltage	S.F. @ 60Hz	EFF.	P.F.	Frame	Design	L.R. Amps
200	149,20	575	1,15	95,4%	0,92	447TS	B	1160

60 Hz								
FLA							Code	F.L. RPM
208	230	416	460	480	575	600		
/	/	/	/	/	170,4	/	G	3580

50 Hz							
FLA			S.F. @ 50Hz	Efficiency	Power Factor	Code	F.L. RPM
190	380	415					
/	/	/	/	/	/	/	/

Wgt. Lbs	PH	Duty	Insul. Class	Amb.	Elevation	Temp. Rise° C
2185	3	Cont.	F	40°C	1000M (3300 Ft)	< 80

% Efficiency		% Power Factor		Torque		Winding Resist. Ω	Safe Cold Start (Secs)
Full Load:	95,4%	Full Load:	0,92	Full Load Ft/Lbs	293,4		
3/4 Load:	94,8%	3/4 Load:	0,90	Locked Rotor %	130		
1/2 Load:	94,3%	1/2 Load:	0,86	Break Down %	240		

Rotor Inertia Wk2 Lb-Ft2	Max Load Inertia Wk2 Lb-Ft2	Shaft Material	Frame Material	DE Bracket Type	ODE Bracket Type	Enclosure	NEMA Rating	Lead Wire Size
27,29	220	Standard	Cast Iron	Standard	Standard	TEFC	IP55	3AWG

Ball Bearings		Grease	Mount Type	Orientation	Paint	Sound Pressure @ 3FT	Sound Power
DE	ODE						
6314	6314	Mobil PolyrexEm	Rigid	Horizontal	Green	95	107

Inverter Duty. Motor meets MG1 parts 31.4.4.2	Constant Torque Range	Variable Torque Range	Constant HP RPM
	10:1	20:1	5400

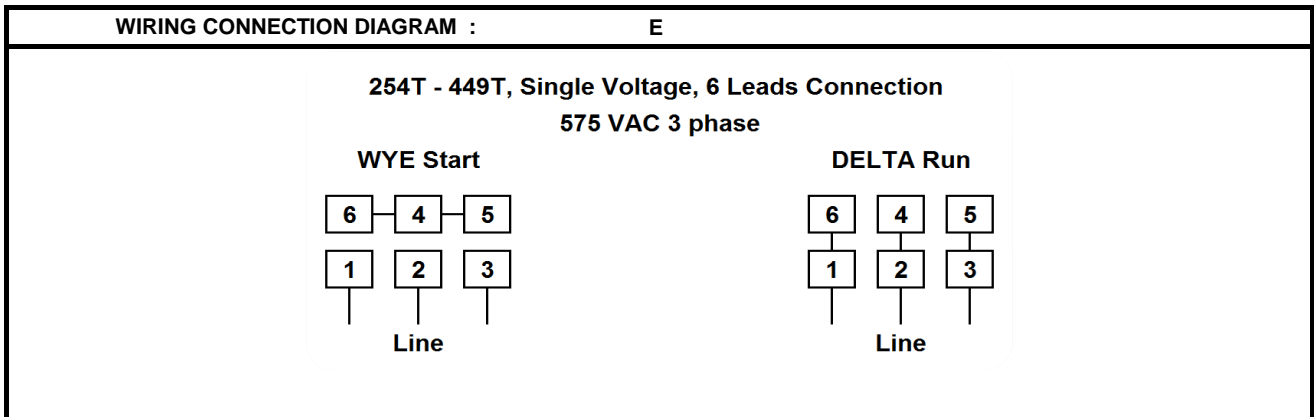

Date: 2020-02-27
 Customer: _____
 Contact: _____
 Submittee: J.C. Lavallée

Catalogue #: MPP-96

NEMA PREMIUM NR CAN NEMA 12 - 12										
HP	VAC	RPM	Enclosure	Frame	Frequency	Design	Poles	LR Code Letter	Insulation Class	Temp. Rise °C
200	575	3580	TEFC	447TS	60	B	2	G	F	< 80
	0Hz	6Hz	15Hz	30Hz	45Hz	60Hz	75Hz	90Hz	105Hz	120Hz
Amps	170,4	170,4	170,4	170,4	170,4	170,4	170,4	170,4	170,4	170,4
RPM	0	358	895	1790	2685	3580	4475	5370	6265	7160
Torq ft.lb	234,73	293,41	293,41	293,41	293,41	293,41	234,73	195,61	167,66	146,70
Peak Tq ft.lb	322,75	645,50	645,50	645,50	645,50	645,50	516,40	430,33	368,86	322,75
HP	0	20,0	50,0	100,0	150,0	200,0	200,0	200,0	200,0	200,0
	Locked Rotor	Pull-Up	Breakdown	Rated Load	Idle	Duty	S. F.	Ambient	Elevation	dBA @ 1M
Speed (RPM)	0,0	1512	2880	3580	3600	Continuous	1,15	40°C	3300 ft	95
Current (Amps)	1160,0	986,0	690,2	170,4	42,8	VFD Rating: Meets MG1 parts 31.4.4.2				
Torque (ft-lbs)	381,4	286,1	704,2	293,4	0,0	C.T.	10:1	V.T.	20:1	

Motor Speed Data

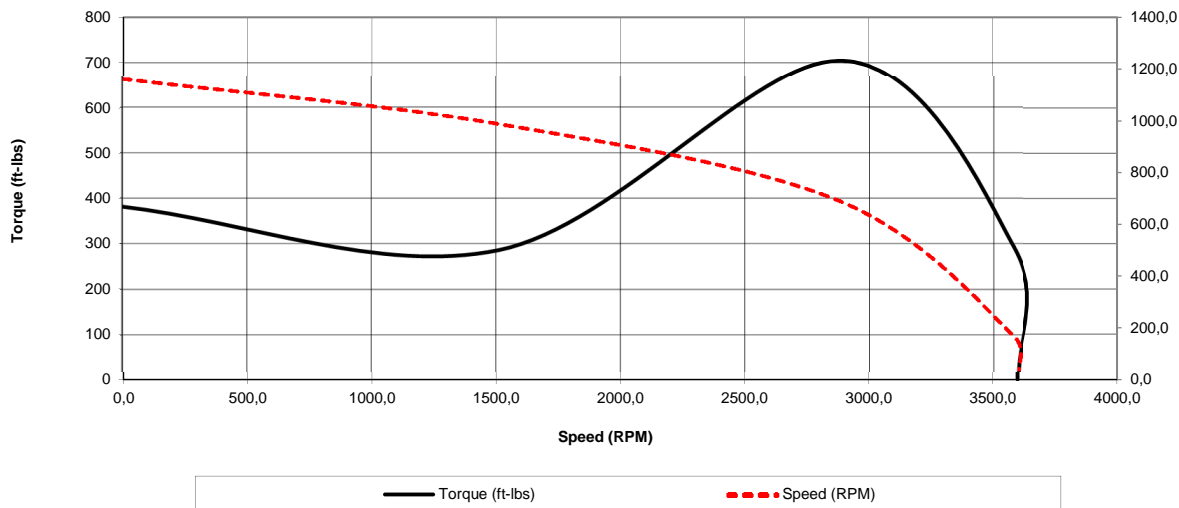

Motor Torque Capability vs RPM

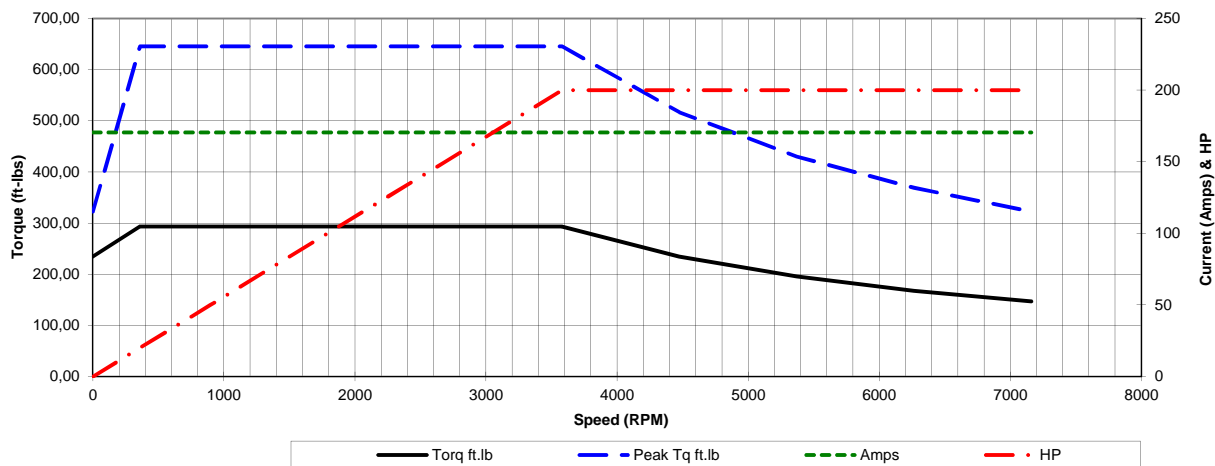

Date: 2020-02-27
 Customer: _____
 Contact: _____
 Submittee: J.C. Lavallée

Catalogue #: **MPP-96**

NEMA PREMIUM NR CAN NEMA 12 - 12										
HP	VAC	RPM	Enclosure	Frame	Frequency	Design	Poles	LR Code Letter	Insulation Class	Temp. Rise °C
200	575	3580	TEFC	447TS	60	B	2	G	F	< 80
Load %	0%	25%	50%	75%	100%	125%	150%			
Amps	42,77	60,92	93,55	130,36	170,40	211,07	257,15			
Torq ft./lbs	0	73,05	146,30	219,75	293,41	367,27	441,34			
RPM	0	3595	3590	3585	3580	3575	3570			
Eff	0	85,39	94,30	94,80	95,40	95,40	95,40			
PF	0	72	86	90	92	93	91,6			
	Locked Rotor	Pull-Up	Breakdown	Rated Load	Idle	Duty	S. F.	Ambient	Elevation	dBA @ 1M
Speed (RPM)	0	1512	2880	3580	3600	Continuous	1,15	40°C	3300 ft	95
Current (Amps)	1160	986,0	690,2	170,4	42,7704	VFD Rating: Meets MG1 parts 31.4.4.2				
Torque (ft.-lbs)	381,43	286,07	704,18	293,41	0,0	C.T.	10:1	V.T.	20:1	

